

RYOBI

OPERATOR'S MANUAL

7-1/4 in. LASER CIRCULAR SAW

DOUBLE INSULATED

CSB132L

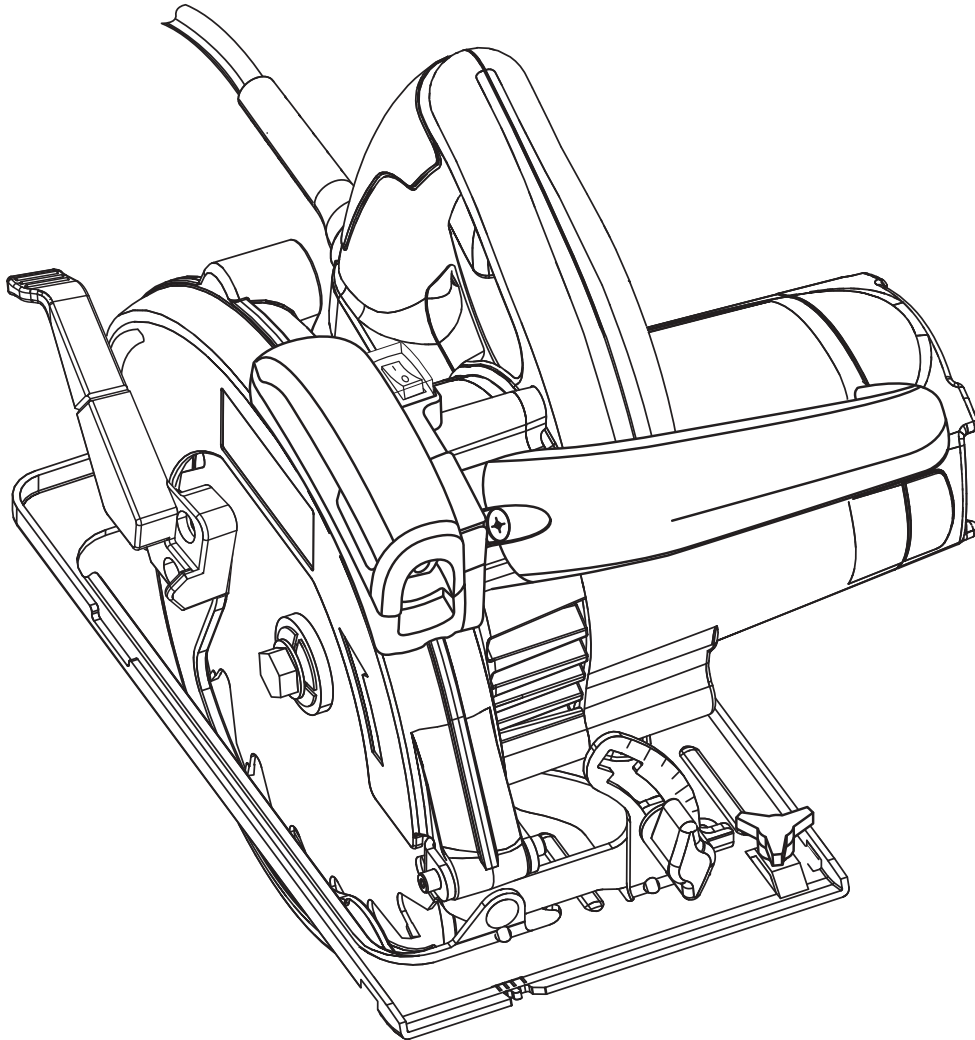

Your circular saw has been engineered and manufactured to our high standard for dependability, ease of operation, and operator safety. When properly cared for, it will give you years of rugged, trouble-free performance.

WARNING: To reduce the risk of injury, the user must read and understand the operator's manual before using this product.

Thank you for your purchase.

SAVE THIS MANUAL FOR FUTURE REFERENCE

TABLE OF CONTENTS

■ Introduction	2
■ Warranty	2
■ General Safety Rules.....	3-4
■ Specific Safety Rules	4-5
■ Symbols	6-7
■ Electrical.....	8
■ Features.....	9-10
■ Assembly.....	10-11
■ Operation.....	12-19
■ Adjustments	20-21
■ Maintenance.....	22
■ Parts Ordering / Service	Back page

INTRODUCTION

This product has many features for making its use more pleasant and enjoyable. Safety, performance, and dependability have been given top priority in the design of this product making it easy to maintain and operate.

WARRANTY

RYOBI® POWER TOOL - LIMITED TWO YEAR WARRANTY AND 30 DAY EXCHANGE POLICY

One World Technologies, Inc., warrants its RYOBI® power tools with the following conditions:

30-DAY EXCHANGE POLICY: During the first 30 days after date of purchase, you may either request service under this warranty or you may exchange any RYOBI® power tool which does not work properly due to defective workmanship or materials by returning the power tool to the dealer from which it was purchased. To receive a replacement power tool or requested warranty service, you must present proof of purchase and return all original equipment packaged with the original product. The replacement power tool will be covered by the limited warranty for the balance of the two year period from the date of the original purchase.

WHAT THIS WARRANTY COVERS: This warranty covers all defects in workmanship or materials in your RYOBI® power tool for a period of two years from the date of purchase. With the exception of batteries, power tool accessories are warranted for ninety (90) days. Batteries are warranted for two years.

HOW TO GET SERVICE: Just return the power tool, properly packaged and postage prepaid, to an Authorized Service Center. You can obtain the location of the Service Center nearest you by contacting a service representative at One World Technologies, Inc., P.O. Box 1207, Anderson, SC 29622-1207, by calling 1-800-525-2579 or by logging on to www.ryobitools.com. When you request warranty service, you must also present proof of purchase documentation, which includes the date of purchase (for example, a bill of sale). We will repair any faulty workmanship, and either repair or replace any defective part, at our option. We will do so without any charge to you. We will complete the work in a reasonable time, but, in any case, within ninety (90) days or less.

WHAT'S NOT COVERED: This warranty applies only to the original purchaser at retail and may not be transferred. This warranty only covers defects arising under normal usage and does not cover any malfunction, failure or defects resulting from misuse, abuse, neglect, alteration, modification or repairs by other than Authorized Service Centers. One World Technologies, Inc. makes no warranties, representations or promises as to the quality or performance of its power tools other than those specifically stated in this warranty.

ADDITIONAL LIMITATIONS: Any implied warranties granted under state law, including warranties of merchantability or fitness for a particular purpose, are limited to two years from the date of purchase. One World Technologies, Inc. is not responsible for direct, indirect, or incidental damages, so the above limitations and exclusions may not apply to you. This warranty gives you specific legal rights, and you may also have other rights which vary from state to state.

GENERAL SAFETY RULES



WARNING:

Read and understand all instructions. Failure to follow all instructions listed below, may result in electric shock, fire and/or serious personal injury.

SAVE THESE INSTRUCTIONS

WORK AREA

- **Keep your work area clean and well lit.** Cluttered benches and dark areas invite accidents.
- **Do not operate power tools in explosive atmospheres, such as in the presence of flammable liquids, gases, or dust.** Power tools create sparks which may ignite the dust or fumes.
- **Keep bystanders, children, and visitors away while operating a power tool.** Distractions can cause you to lose control.

ELECTRICAL SAFETY

- **Double insulated tools are equipped with a polarized plug (one blade is wider than the other). This plug will fit in a polarized outlet only one way. If the plug does not fit fully in the outlet, reverse the plug. If it still does not fit, contact a qualified electrician to install a polarized outlet. Do not change the plug in any way.** Double insulation  eliminates the need for the three-wire grounded power cord and grounded power supply system.
- **Avoid body contact with grounded surfaces such as pipes, radiators, ranges, and refrigerators.** There is an increased risk of electric shock if your body is grounded.
- **Don't expose power tools to rain or wet conditions.** Water entering a power tool will increase the risk of electric shock.
- **Do not abuse the cord. Never use the cord to carry the tools or pull the plug from an outlet. Keep cord away from heat, oil, sharp edges, or moving parts. Replace damaged cords immediately.** Damaged cords increase the risk of electric shock.
- **When operating a power tool outside, use an outdoor extension cord marked "W-A" or "W".** These cords are rated for outdoor use and reduce the risk of electric shock.

PERSONAL SAFETY

- **Stay alert, watch what you are doing and use common sense when operating a power tool. Do not use tool while tired or under the influence of drugs, alcohol, or medication.** A moment of inattention while operating power tools may result in serious personal injury.
- **Dress properly. Do not wear loose clothing or jewelry. Contain long hair. Keep your hair, clothing, and gloves away from moving parts.** Loose clothes, jewelry, or long hair can be caught in moving parts.

- **Avoid accidental starting. Be sure switch is off before plugging in.** Carrying tools with your finger on the switch or plugging in tools that have the switch on invites accidents.
- **Remove adjusting keys or wrenches before turning the tool on.** A wrench or a key that is left attached to a rotating part of the tool may result in personal injury.
- **Do not overreach. Keep proper footing and balance at all times.** Proper footing and balance enables better control of the tool in unexpected situations.
- **Use safety equipment. Always wear eye protection.** Dust mask, nonskid safety shoes, hard hat, or hearing protection must be used for appropriate conditions.
- **Do not wear loose clothing or jewelry. Contain long hair.** Loose clothes, jewelry, or long hair can be drawn into air vents.
- **Do not use on a ladder or unstable support.** Stable footing on a solid surface enables better control of the tool in unexpected situations.

TOOL USE AND CARE

- **Use clamps or other practical way to secure and support the workpiece to a stable platform.** Holding the work by hand or against your body is unstable and may lead to loss of control.
- **Do not force tool. Use the correct tool for your application.** The correct tool will do the job better and safer at the rate for which it is designed.
- **Do not use tool if switch does not turn it on or off.** Any tool that cannot be controlled with the switch is dangerous and must be repaired.
- **Disconnect the plug from the power source before making any adjustments, changing accessories, or storing the tool.** Such preventive safety measures reduce the risk of starting the tool accidentally.
- **Store idle tools out of reach of children and other untrained persons.** Tools are dangerous in the hands of untrained users.
- **Maintain tools with care. Keep cutting tools sharp and clean.** Properly maintained tools, with sharp cutting edges are less likely to bind and are easier to control.
- **Check for misalignment or binding of moving parts, breakage of parts, and any other condition that may affect the tools operation. If damaged, have the tool serviced before using.** Many accidents are caused by poorly maintained tools.
- **Use only accessories that are recommended by the manufacturer for your model.** Accessories that may be suitable for one tool, may become hazardous when used on another tool.
- **Keep the tool and its handle dry, clean and free from oil and grease.** Always use a clean cloth when cleaning. Never use brake fluids, gasoline, petroleum-based products, or any strong solvents to clean your tool. Following this rule will reduce the risk of loss of control and deterioration of the enclosure plastic.

GENERAL SAFETY RULES

SERVICE

- **Tool service must be performed only by qualified repair personnel.** Service or maintenance performed by unqualified personnel could result in a risk of injury.
- **When servicing a tool, use only identical replacement parts. Follow instructions in the Maintenance section of this manual.** Use of unauthorized parts or failure to follow Maintenance Instructions may create a risk of electric shock or injury.

SPECIFIC SAFETY RULES

- **DANGER! Keep hands away from cutting area and blade. Keep your second hand on the auxiliary handle or motor housing.** If both hands are holding the saw, they cannot be cut by the blade.
 - **Keep your body positioned to either side of the saw blade, but not in line with the saw blade.** KICKBACK could cause the saw to jump backwards. (See "Causes And Operator Prevention Of Kickback" later.)
 - **Do not reach underneath the work.** The guard cannot protect you from the blade below the work.
 - **Check lower guard for proper closing before each use. Do not operate saw if lower guard does not move freely and close instantly. Never clamp or tie the lower guard into the open position.** If saw is accidentally dropped, lower guard may be bent. Raise the lower guard with the retracting handle. Make sure it moves freely and does not touch the blade or any other part, in all angles and depths of cut.
 - **Check the operation and condition of the lower guard spring. If the guard and the spring are not operating properly, they must be serviced before use.** Lower guard may operate sluggishly due to damaged parts, gummy deposits, or a buildup of debris.
 - **Lower guard should be retracted manually only for special cuts, such as "Pocket Cuts" and "Compound Cuts." Raise lower guard by retracting handle. As soon as blade enters the material, lower guard must be released.** For all other sawing, the lower guard should operate automatically.
 - **Always observe that the lower guard is covering the blade before placing saw down on bench or floor.** An unprotected, coasting blade will cause the saw to walk backwards, cutting whatever is in its path. Be aware of the time it takes for the blade to stop after switch is released.
 - **NEVER hold piece being cut in your hands or across your leg.** It is important to support the work properly to minimize body exposure, blade binding, or loss of control.
 - **Hold tool by insulated gripping surfaces when performing an operation where the cutting tool may contact hidden wiring or its own cord.** Contact with a "live" wire will make exposed metal parts of the tool "live" and shock the operator.
 - **When ripping, always use a rip fence or straight edge guide.** This improves the accuracy of the cut and reduces the chance for blade binding.
 - **Always use blades with correct size and shape (diamond vs. round) arbor holes.** Blades that do not match the mounting hardware of the saw will run eccentrically, causing loss of control.
 - **Never use damaged or incorrect blade washers or bolts.** The blade washers and bolts were specially designed for the saw for optimum performance and safety of operation.
- ## CAUSES AND OPERATOR PREVENTION OF KICKBACK:
- Kickback is a sudden reaction to a pinched, bound, or misaligned saw blade, causing an uncontrolled saw to lift up and out of the workpiece toward the operator.
- When the blade is pinched or bound tightly by the kerf closing down, the blade stalls and the motor reaction drives the unit rapidly back toward the operator.
- If the blade becomes twisted or misaligned in the cut, the teeth at the back edge of the blade can dig into the top surface of the wood causing the blade to climb out of the kerf and jump back toward the operator.
- Kickback is the result of tool misuse and/or incorrect operating procedures or conditions and can be avoided by taking proper precautions, as given below:
- **Maintain a firm grip with both hands on the saw and position your body and arm to allow you to resist KICKBACK forces.** KICKBACK forces can be controlled by the operator, if proper precautions are taken.
 - **When blade is binding, or when interrupting a cut for any reason, release the trigger and hold the saw motionless in the material until the blade comes to a complete stop. Never attempt to remove the saw from the work or pull the saw backward while the blade is in motion, or KICKBACK may occur.** Investigate and take corrective actions to eliminate the cause of blade binding.
 - **When restarting a saw in the workpiece, center the saw blade in the kerf and check that saw teeth are not engaged into the material.** If saw blade is binding, it may walk up or KICKBACK from the workpiece as the saw is restarted.
 - **Support large panels to minimize the risk of blade pinching and KICKBACK.** Large panels tend to sag under their own weight. Supports must be placed under the panel on both sides, near the line of cut and near the edge of the panel.

SPECIFIC SAFETY RULES











- **Do not use dull or damaged blade.** Unsharpened or improperly set blades produce narrow kerf which causes excessive friction, blade binding and KICKBACK.
- **Blade depth and bevel adjusting locking levers must be tight and secure before making cut.** If blade adjustment shifts while cutting, it may cause binding and KICKBACK.
- **Use extra caution when making a “Pocket Cut” into existing walls or other blind areas.** The protruding blade may cut objects that can cause KICKBACK.
- **Know your power tool. Read operator’s manual carefully. Learn its applications and limitations, as well as the specific potential hazards related to this tool.** Following this rule will reduce the risk of electric shock, fire, or serious injury.
- **Always wear safety glasses. Everyday eyeglasses have only impact-resistant lenses; they are NOT safety glasses.** Following this rule will reduce the risk of serious personal injury.
- **Protect your lungs. Wear a face or dust mask if the operation is dusty.** Following this rule will reduce the risk of serious personal injury.
- **Protect your hearing. Wear hearing protection during extended periods of operation.** Following this rule will reduce the risk of serious personal injury.
- **Inspect tool cords periodically and, if damaged, have repaired at your nearest authorized service center. Constantly stay aware of cord location.** Following this rule will reduce the risk of electric shock or fire.
- **Check damaged parts. Before further use of the tool, a guard or other part that is damaged should be carefully checked to determine that it will operate properly and perform its intended function. Check for alignment of moving parts, binding of moving parts, breakage of parts, mounting, and any other conditions that may affect its operation. A guard or other part that is damaged should be properly repaired or replaced by an authorized service center.** Following this rule will reduce the risk of shock, fire, or serious injury.
- **Make sure your extension cord is in good condition. When using an extension cord, be sure to use one heavy enough to carry the current your product will draw. A wire gage size (A.W.G.) of at least 12 is recommended for an extension cord 50 feet or less in length. A cord exceeding 100 feet is not recommended. If in doubt, use the next heavier gage. The smaller the gage number, the heavier the cord. An undersized cord will cause a drop in line voltage resulting in loss of power and overheating.**
- **Inspect for and remove all nails from lumber before using this tool.** Following this rule will reduce the risk of serious personal injury.
- **If the power supply cord is damaged, it must be replaced only by the manufacturer or by an authorized service center to avoid risk.**

LASER GUIDE WARNINGS:

- **Avoid** direct eye exposure when using the laser guide.
- The laser shall be used and maintained in accordance with the manufacturer’s instructions.
- Never aim the beam at a person or object other than the workpiece.
- Always ensure the laser beam is aimed at a sturdy workpiece without reflective surfaces. Shiny reflective sheet metal or similar shiny materials are not suitable for laser use.
- All repairs should be made by an authorized service representative or the laser manufacturer.
- **Save these instructions.** Refer to them frequently and use them to instruct others who may use this tool. If you loan someone this tool, loan them these instructions also.



SYMBOLS

Some of the following symbols may be used on this product. Please study them and learn their meaning. Proper interpretation of these symbols will allow you to operate the product better and safer.

SYMBOL	NAME	DESIGNATION/EXPLANATION
V	Volts	Voltage
A	Amperes	Current
Hz	Hertz	Frequency (cycles per second)
W	Watt	Power
min	Minutes	Time
~	Alternating Current	Type of current
≡	Direct Current	Type or a characteristic of current
n_0	No Load Speed	Rotational speed, at no load
	Class II Tool	Double-insulated construction
.../min	Per Minute	Revolutions, strokes, surface speed, orbits etc., per minute
	Wet Conditions Alert	Do not expose to rain or use in damp locations.
	Read The Operator's Manual	To reduce the risk of injury, user must read and understand operator's manual before using this product.
	Eye Protection	Always wear safety goggles or safety glasses with side shields and, as necessary, a full face shield when operating this product.
	Safety Alert	Precautions that involve your safety.
	No Hands Symbol	Failure to keep your hands away from the blade will result in serious personal injury.
	No Hands Symbol	Failure to keep your hands away from the blade will result in serious personal injury.
	No Hands Symbol	Failure to keep your hands away from the blade will result in serious personal injury.
	No Hands Symbol	Failure to keep your hands away from the blade will result in serious personal injury.
	Hot Surface	To reduce the risk of injury or damage, avoid contact with any hot surface.

SYMBOLS

The following signal words and meanings are intended to explain the levels of risk associated with this product.

SYMBOL	SIGNAL	MEANING
	DANGER:	Indicates an imminently hazardous situation, which, if not avoided, will result in death or serious injury.
	WARNING:	Indicates a potentially hazardous situation, which, if not avoided, could result in death or serious injury.
	CAUTION:	Indicates a potentially hazardous situation, which, if not avoided, may result in minor or moderate injury.
	CAUTION:	(Without Safety Alert Symbol) Indicates a situation that may result in property damage.

SERVICE

Servicing requires extreme care and knowledge and should be performed only by a qualified service technician. For service we suggest you return the product to the nearest **AUTHORIZED SERVICE CENTER** for repair. When servicing, use only identical replacement parts.

WARNING:

To avoid serious personal injury, do not attempt to use this product until you read thoroughly and understand completely the operator's manual. If you do not understand the warnings and instructions in the operator's manual, do not use this product. Call Ryobi customer service for assistance.

WARNING:



The operation of any power tool can result in foreign objects being thrown into your eyes, which can result in severe eye damage. Before beginning power tool operation, always wear safety goggles or safety glasses with side shields and, when needed, a full face shield. We recommend Wide Vision Safety Mask for use over eyeglasses or standard safety glasses with side shields. Always use eye protection which is marked to comply with ANSI Z87.1.

SAVE THESE INSTRUCTIONS

ELECTRICAL

DOUBLE INSULATION

Double insulation is a concept in safety in electric power tools, which eliminates the need for the usual three-wire grounded power cord. All exposed metal parts are isolated from the internal metal motor components with protecting insulation. Double insulated tools do not need to be grounded.

WARNING:

The double insulated system is intended to protect the user from shock resulting from a break in the tool's internal insulation. Observe all normal safety precautions to avoid electrical shock.

NOTE: Servicing of a product with double insulation requires extreme care and knowledge of the system and should be performed only by a qualified service technician. For service, we suggest you return the product to your nearest authorized service center for repair. Always use original factory replacement parts when servicing.

ELECTRICAL CONNECTION

This product has a precision-built electric motor. It should be connected to a **power supply that is 120 volts, 60 Hz, AC only (normal household current)**. Do not operate this product on direct current (DC). A substantial voltage drop will cause a loss of power and the motor will overheat. If the product does not operate when plugged into an outlet, double-check the power supply.

EXTENSION CORDS

When using a power tool at a considerable distance from a power source, be sure to use an extension cord that has the capacity to handle the current the product will draw. An undersized cord will cause a drop in line voltage, resulting in overheating and loss of power. Use the chart to determine the minimum wire size required in an extension cord. Only round jacketed cords listed by Underwriter's Laboratories (UL) should be used.

When working outdoors with a product, use an extension cord that is designed for outside use. This type of cord is designated with "WA" on the cord's jacket.

Before using any extension cord, inspect it for loose or exposed wires and cut or worn insulation.

**Ampere rating (on product data plate)

Cord Length	Wire Size (A.W.G.)					
	0-2.0	2.1-3.4	3.5-5.0	5.1-7.0	7.1-12.0	12.1-16.0
25'	16	16	16	16	14	14
50'	16	16	16	14	14	12
100'	16	16	14	12	10	—

**Used on 12 gauge - 20 amp circuit.

NOTE: AWG = American Wire Gauge

WARNING:

Keep the extension cord clear of the working area. Position the cord so that it will not get caught on lumber, tools, or other obstructions while you are working with a power tool. Failure to do so can result in serious personal injury.

WARNING:

Check extension cords before each use. If damaged replace immediately. Never use the product with a damaged cord since touching the damaged area could cause electrical shock resulting in serious injury.

FEATURES

PRODUCT SPECIFICATIONS

- Blade Diameter 7-1/4 in.
- Blade Arbor 5/8 in.
- Cutting Depth at 0° 2-3/8 in.
- Cutting Depth at 45° 1-13/16 in.
- Input 120 V, 60 Hz, AC Only, 13 Amps
- No Load Speed 5,500 r/min. (RPM)
- Net Weight 12 lbs.
- Laser Guide Class IIIa, <5mW max, 650nm

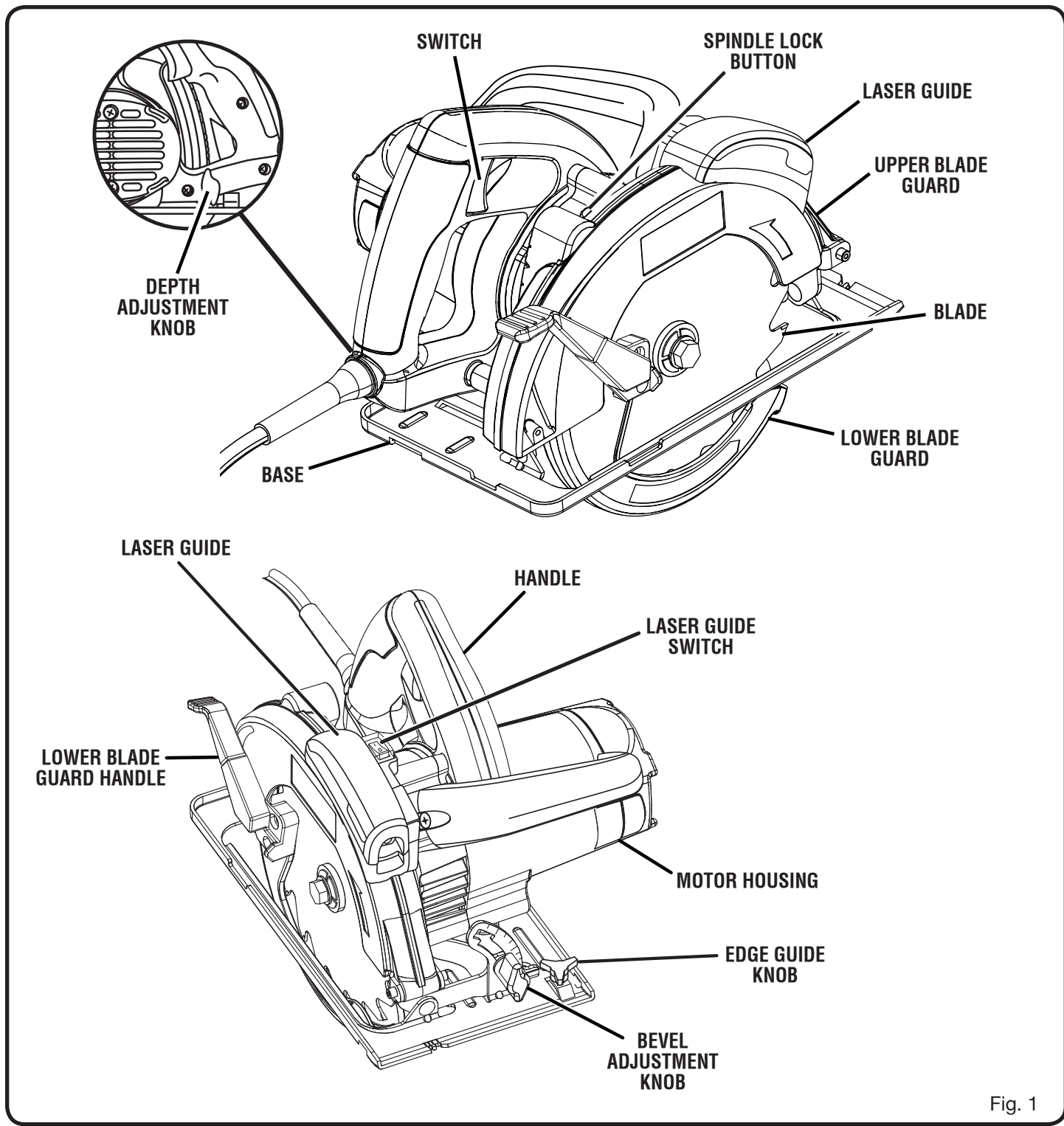

Fig. 1

FEATURES

KNOW YOUR LASER CIRCULAR SAW

See Figure 1.

The safe use of this product requires an understanding of the information on the product and in this operator's manual as well as a knowledge of the project you are attempting. Before use of this product, familiarize yourself with all operating features and safety rules.

ERGONOMIC DESIGN

The design of your circular saw provides for maintaining proper two hand control when cutting. It has been designed to be comfortable and easy to grasp.

LASER GUIDE

The laser guide will generate a red line on the work surface when turned on.

SPINDLE LOCK

The spindle lock allows you to secure the blade when turning the blade screw.

SWITCH

The circular saw is equipped with a pre-travel safety switch which reduces the possibility of accidental starting. When you depress the switch, the saw will not start until you reach the pre-travel position. You must depress the switch fully to activate the saw.

ASSEMBLY

UNPACKING

This product requires assembly.

- Carefully remove the product and any accessories from the box. Make sure that all items listed in the packing list are included.
- Inspect the product carefully to make sure no breakage or damage occurred during shipping.
- Do not discard the packing material until you have carefully inspected and satisfactorily operated the product.
- If any parts are damaged or missing, please call 1-800-525-2579 for assistance.

PACKING LIST

Circular Saw with Laser

7-1/4 in. Blade

AAA Batteries (2)

Wrench

Operator's Manual

WARNING:

If any parts are damaged or missing do not operate this product until the parts are replaced. Failure to heed this warning could result in serious personal injury.

WARNING:

Do not attempt to modify this product or create accessories not recommended for use with this product. Any such alteration or modification is misuse and could result in a hazardous condition leading to possible serious personal injury.

WARNING:

Do not connect to power supply until assembly is complete. Failure to comply could result in accidental starting and possible serious personal injury.

WARNING:

A 7-1/4 in. blade is the maximum blade capacity of the saw. Also, never use a blade that is too thick to allow outer blade washer to engage with the flat on the spindle. Larger blades will come in contact with the blade guards, while thicker blades will prevent blade screw from securing blade on spindle. Either of these situations could result in a serious accident.

ASSEMBLY

CAUTION:

To prevent damage to the spindle or spindle lock, always allow motor to come to a complete stop before engaging spindle lock.

ATTACHING BLADE

See Figures 2 - 3.

- Unplug the saw.
- Depress and hold spindle lock.
- Remove blade screw by turning it counterclockwise with the provided wrench, while keeping the spindle lock depressed.
- Remove spring washer and outer blade washer ("D" washer).

⚠ WARNING:

If inner flange bushing has been removed, replace it before placing blade on spindle. Failure to do so could cause an accident since blade will not tighten properly.

- Retract the lower blade guard into the upper blade guard using the lower blade guard handle. Make sure the lower guard spring works properly, allowing the guard to move freely.
- Check to see that the saw teeth and arrow on the saw blade and the arrow on the lower guard are pointing in the same direction.

NOTE: The saw teeth point upward at the front of the saw as shown.

- Fit the saw blade inside the lower blade guard and onto the spindle.
- Reinstall "D" washer.
- Reinstall spring washer.
- Depress and hold spindle lock and replace blade screw.
- Tighten blade screw securely by turning it clockwise with the wrench.

NOTE: Never use a blade that is too thick to allow the "D" washer to engage with the flat on the spindle.

REMOVING BLADE

See Figure 4.

- Unplug the saw.
- Depress and hold spindle lock.
- Remove blade screw by turning it counterclockwise with the provided wrench, while keeping the spindle lock depressed.
- Remove spring washer and outer blade washer ("D" washer).
- Lift lower blade guard.
- Remove blade.

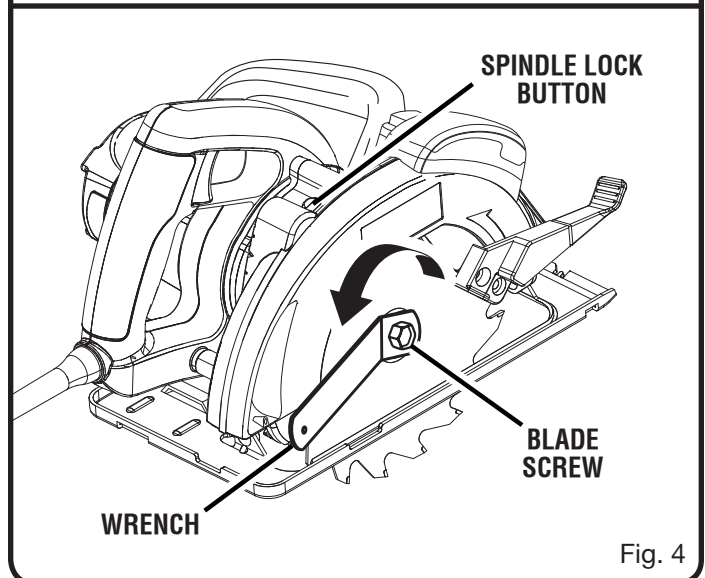
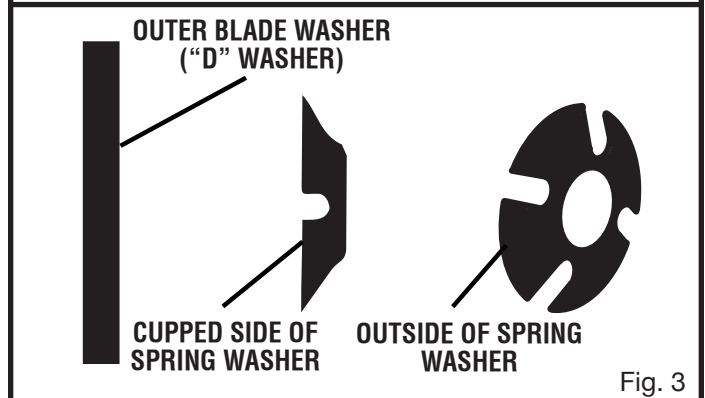
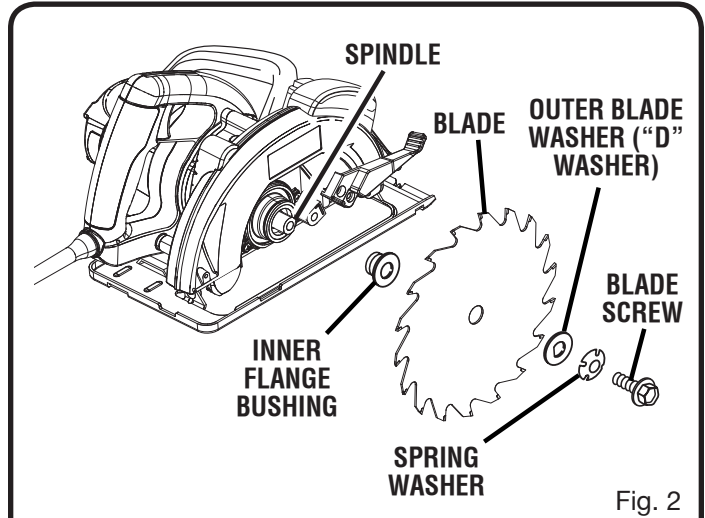

OPERATION

⚠ WARNING:

Do not allow familiarity with products to make you careless. Remember that a careless fraction of a second is sufficient to inflict serious injury.

⚠ WARNING:

Always wear safety goggles or safety glasses with side shields when operating power tools. Failure to do so could result in objects being thrown into your eyes resulting in possible serious injury.

⚠ WARNING:

Do not use any attachments or accessories not recommended by the manufacturer of this product. The use of attachments or accessories not recommended can result in serious personal injury.

APPLICATIONS

You may use this product for the purposes listed below:

- Cutting all types of wood products (lumber, plywood, paneling)
- Cross Cutting/Rip Cutting
- Bevel Cutting
- Pocket Cutting

KICKBACK

See Figures 5 - 8.

Kickback occurs when the blade stalls rapidly and the saw is driven back towards you. Blade stalling is caused by any action which pinches the blade in the wood.

⚠ DANGER:

Release switch immediately if blade binds or saw stalls. Kickback could cause you to lose control of the saw. Loss of control can lead to serious injury.

To guard against kickback, avoid dangerous practices such as the following.

- Setting blade depth incorrectly.
- Sawing into knots or nails in workpiece.
- Twisting the blade while making a cut.
- Making a cut with a dull, gummed up, or improperly set blade.
- Supporting the workpiece incorrectly.
- Forcing a cut.
- Cutting warped or wet lumber.
- Operating the tool incorrectly or misusing the tool.

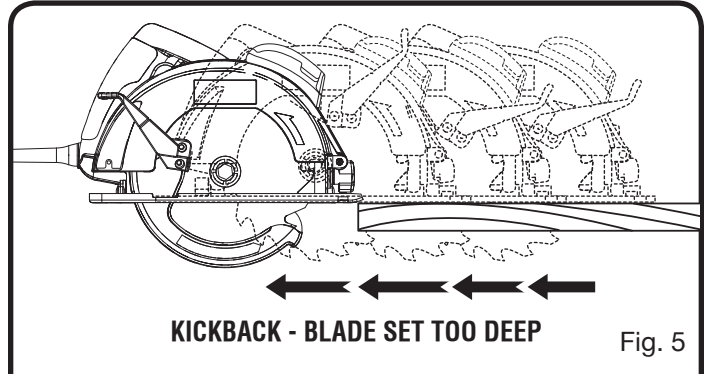

INCORRECT SUPPORT

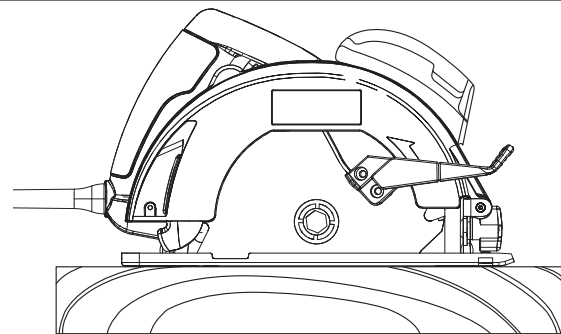
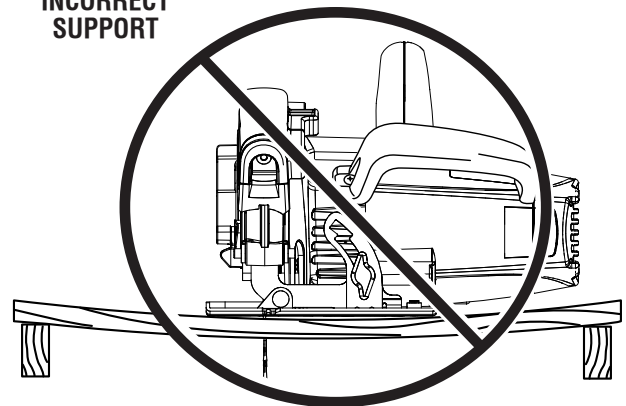

CORRECT BLADE DEPTH SETTING = BLADE EXPOSED 1/4 in. OR LESS ON UNDERSIDE OF WORKPIECE

Fig. 7

CORRECT SUPPORT

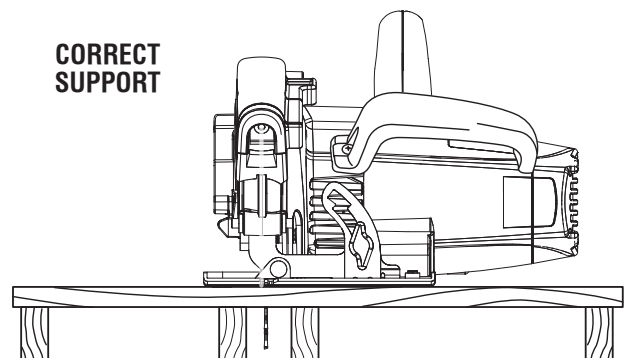

OPERATION

To lessen the chance of kickback, follow these safety practices.

- Keep the blade at the correct depth setting. The depth setting should not exceed 1/4 in. below the material being cut.
- Inspect the workpiece for knots or nails before cutting. Never saw into a knot or nail.
- Make straight cuts. Always use a straight edge guide when rip cutting. This helps prevent twisting the blade.
- Use clean, sharp, and properly set blades. Never make cuts with dull blades.
- Support the workpiece properly before beginning a cut.
- Use steady, even pressure when making a cut. Never force a cut.
- Do not cut warped or wet lumber.
- Hold the saw firmly with both hands and keep your body in a balanced position so as to resist the forces if kickback should occur.

⚠ WARNING:

When using the saw, always stay alert and exercise control. Do not remove the saw from the workpiece while the blade is moving.

SAW BLADES

The best of saw blades will not cut efficiently if they are not kept clean, sharp, and properly set. Using a dull blade will place a heavy load on the saw and increase the danger of kickback. Keep extra blades on hand so that sharp blades are always available.

Gum and wood pitch hardened on blades will slow the saw down. Remove saw blade from the saw and use gum and pitch remover, hot water, or kerosene to remove these accumulations. **DO NOT USE GASOLINE.**

BLADE GUARD SYSTEM

See Figure 9.

The lower blade guard attached to the circular saw is there for your protection and safety. Do not alter it for any reason. If it becomes damaged, do not operate the saw until you have the guard repaired or replaced. Always leave guard in operating position when using the saw.

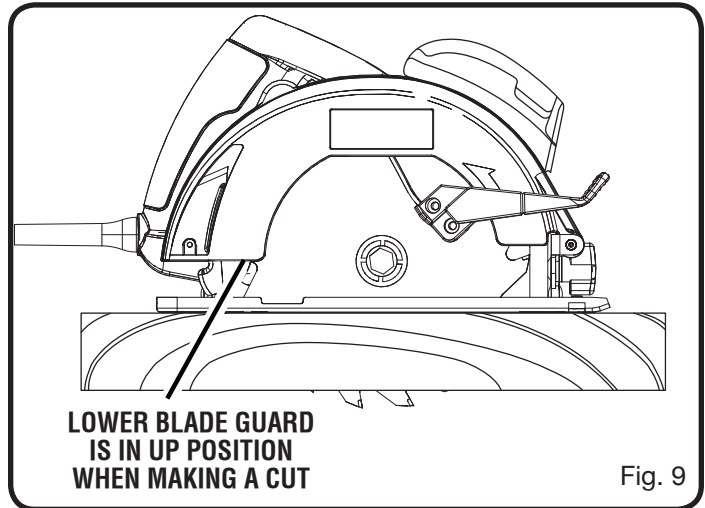

⚠ DANGER:

When sawing through work, lower blade guard does not cover blade on the underside of work. Since blade is exposed on underside of work, keep hands and fingers away from cutting area. Any part of your body coming in contact with moving blade will result in serious injury.

⚠ CAUTION:

Never use saw when guard is not operating correctly. Check the guard for correct operation before each use. The guard is operating correctly when it moves freely and readily returns to the closed position. If you drop the saw, check the lower blade guard and bumper for damage at all depth settings before reuse.

OPERATION

ADJUSTING BLADE DEPTH

See Figure 10.

Always keep correct blade depth setting. The correct blade depth setting for all cuts should not exceed 1/4 in. below the material being cut. More blade depth will increase the chance of kickback and cause the cut to be rough. For more depth of cut accuracy, a scale is located on the upper blade guard.

- Unplug the saw.

⚠ WARNING:

Failure to unplug the tool could result in accidental starting causing serious injury.

- Loosen depth adjustment knob.
- Determine the desired depth of cut.
- Locate depth of cut scale on back of upper blade guard.
- Hold base flat against the workpiece and raise or lower saw until the indicator mark on bracket aligns with notch on blade guard.
- Tighten depth adjustment knob securely.

STARTING/STOPPING THE SAW

See Figure 11.

To start the saw: Depress the switch trigger.

Always let the blade reach full speed, then guide the saw into the workpiece.

⚠ WARNING:

The blade coming in contact with the workpiece before it reaches full speed could cause the saw to “kickback” towards you resulting in serious injury.

To stop the saw: Release the switch trigger.

After you release the switch trigger, allow the blade to come to a complete stop. **Do not remove the saw from the workpiece while the blade is moving.**

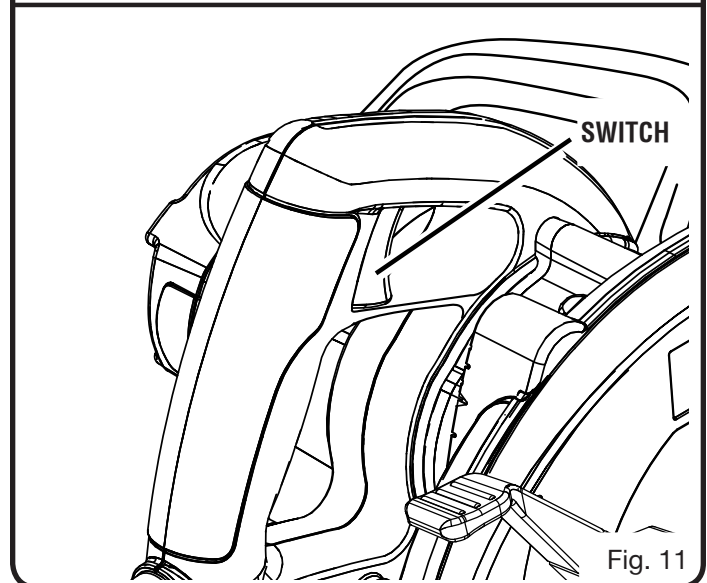
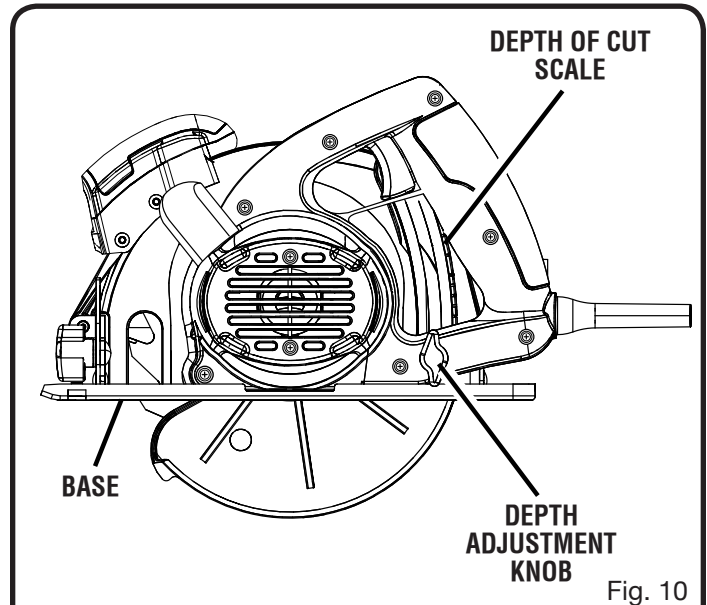

OPERATION

OPERATING THE SAW

See Figures 12 - 14.

It is important to understand the correct method for operating the saw. Refer to the figures in this section to learn the correct and incorrect ways for handling the saw.

⚠ WARNING:

To make sawing easier and safer, always maintain proper control of the saw. Loss of control could cause an accident resulting in possible serious injury.

⚠ DANGER:

When lifting the saw from the workpiece, the blade is exposed on the underside of the saw until the lower blade guard closes. Make sure the lower blade guard is closed before setting the saw down.

To make the best possible cut, follow these helpful hints.

- Hold the saw firmly with both hands.
- Avoid placing your hand on the workpiece while making a cut.
- Support the workpiece so that the cut is always on your right.
- Support the workpiece near the cut.
- Clamp the workpiece securely so that the workpiece will not move during the cut.
- Avoid placing the saw on the part of the workpiece that will fall off when the cut is made.
- Place the workpiece with the “good” side down.
- Draw a guideline along the desired line of cut before beginning your cut.
- Keep the cord away from the cutting area. Always place the cord to prevent it from hanging up on the workpiece while making a cut.

⚠ DANGER:

If the cord hangs up on the workpiece during a cut, release the switch trigger immediately. Unplug the saw and reposition the cord to prevent it from hanging up again.

⚠ DANGER:

Using a saw with a damaged cord could result in serious injury or death. If the cord has been damaged, have it replaced before using the saw again.

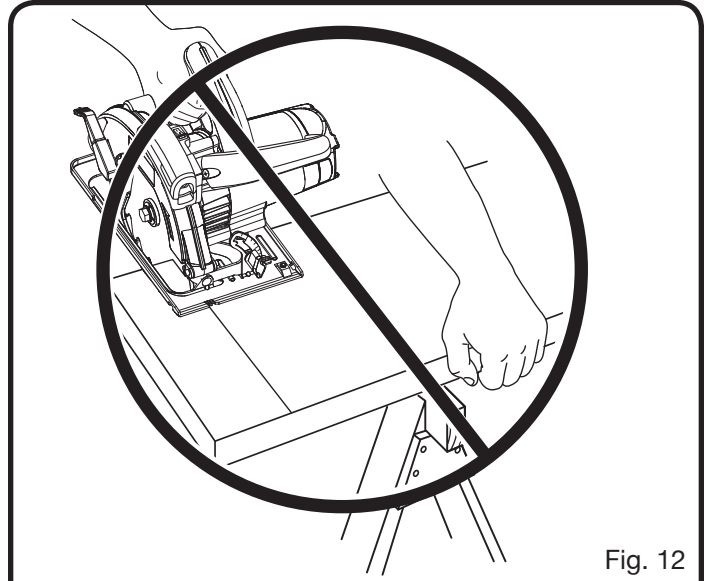

Fig. 12

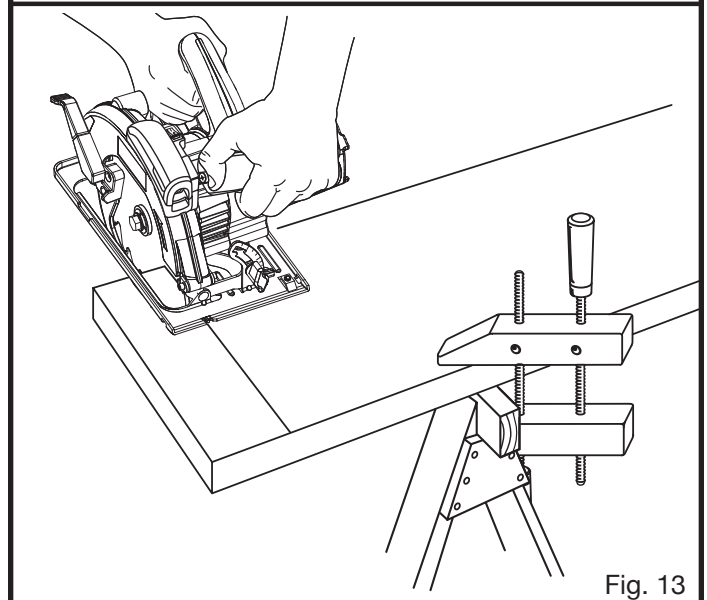

Fig. 13

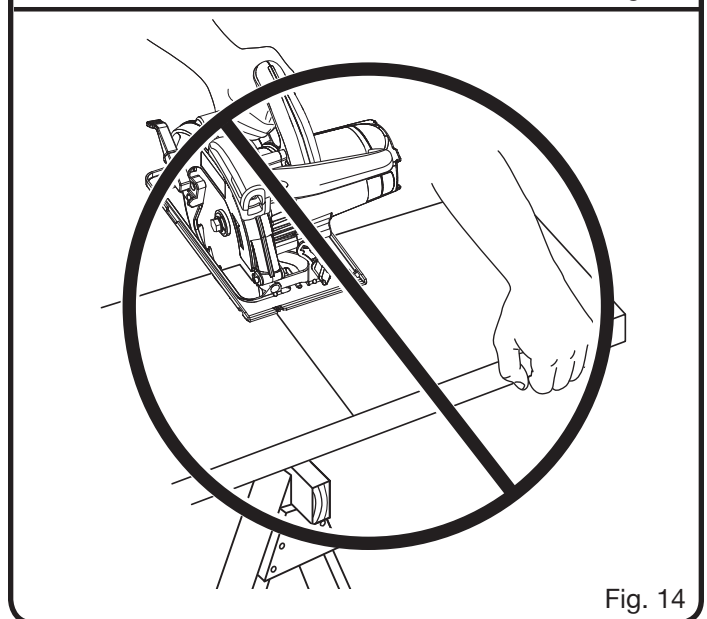

Fig. 14

OPERATION

CROSS CUTTING/RIP CUTTING

See Figure 15.

When making a cross cut or rip cut, align the line of cut with the outer blade guide notch on the base as shown in the figure.

Since blade thicknesses vary, always make a trial cut in scrap material along a guideline to determine how much, if any, you must offset the guideline to produce an accurate cut.

NOTE: The distance from the line of cut to the guideline is the amount you should offset the guide.

TO RIP CUT

See Figures 16 - 17.

Use a guide when making long or wide rip cuts with the saw.

To rip cut using optional edge guide:

- Slide edge guide into the slot.
- Align the guideline with the blade guide notch on the base.
- Adjust the guide so that the “0” on the guide is aligned with the edge of the workpiece.
- Secure the guide with the lock knob provided with the saw.
- Secure the workpiece.
- Position the face of the edge guide firmly against the edge of workpiece.

NOTE: The guiding edge of the workpiece must be straight for your cut to be straight. Use caution to prevent the blade from binding in the cut.

- Saw along workpiece keeping guide firmly against edge to achieve a straight rip cut.

To rip cut using a straight edge:

- Secure the workpiece.
- Clamp a straight edge to the workpiece using C-clamps.

NOTE: Position C-clamps so they will not interfere with the saw housing during the cut.

- Saw along the straight edge to achieve a straight rip cut.

NOTE: Do not bind the blade in the cut.

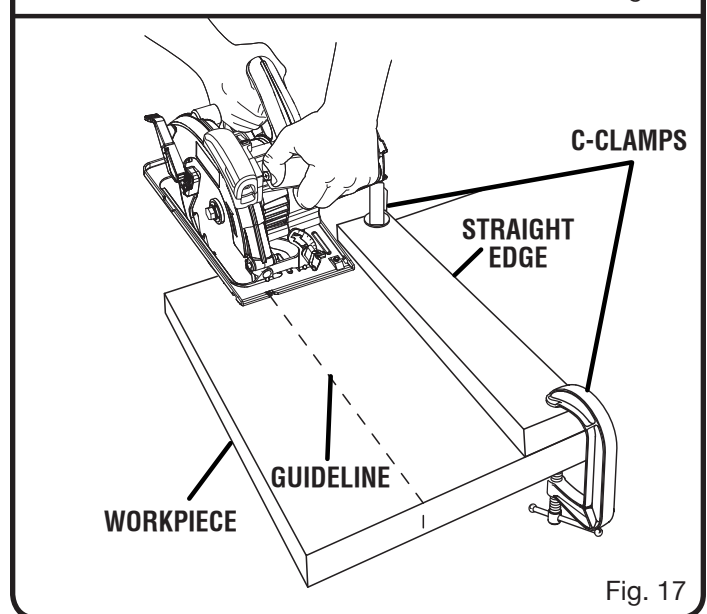
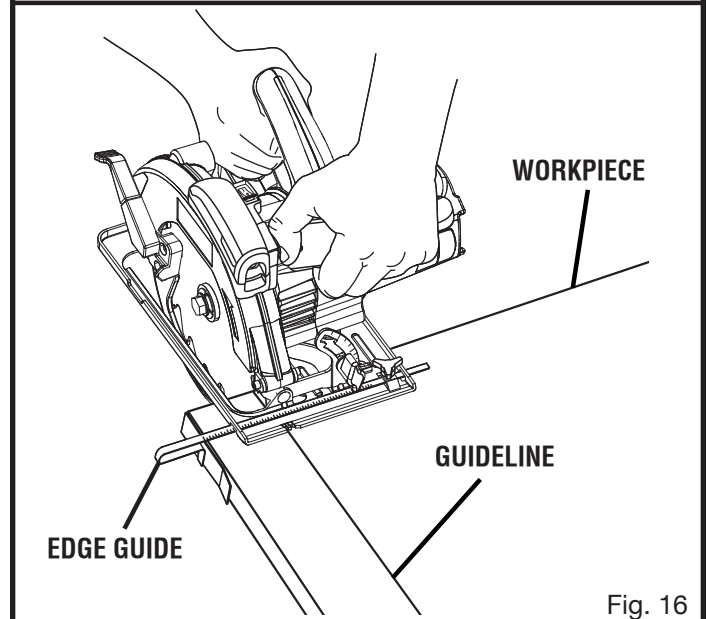
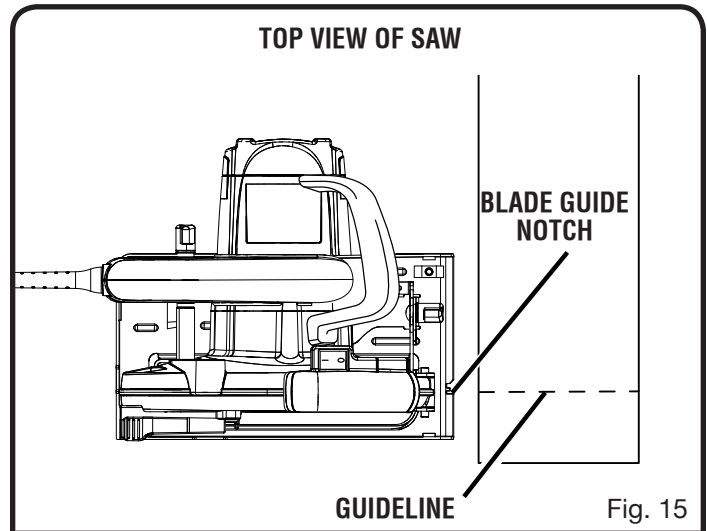

OPERATION

LENGTH OF CUT SCALE

See Figure 18.

The saw is equipped with a length of cut scale on its base. It is parallel with the saw blade and you can use it to measure the distance into the material the blade cuts.

NOTE: Six inches is the maximum length of cut that you can measure. Also, it is accurate only when the depth of cut is set at full maximum depth.

USING THE LASER GUIDE

See Figure 19.

WARNING:

Do not stare into the laser beam or turn the laser on when the tool is not in use. Failure to heed this warning could result in serious personal injury. The laser unit comes from the factory already installed and aligned. If the laser becomes misaligned after time, refer to the *Adjustments* section.

- Mark the line to be cut on the workpiece.
- Adjust the depth and angle of the cut as needed.
- Switch **ON (I)** the laser beam.
- Plug the tool into a power supply and start the motor.
NOTE: Do not touch the blade to the workpiece until the saw has reached maximum speed.
- Slowly push the saw forward into the workpiece.
NOTE: Keep the laser beam on the marked line on the workpiece for precision cutting.
- Once the cut is complete, allow the saw to come to a complete stop before turning off the laser.
- Unplug the saw.

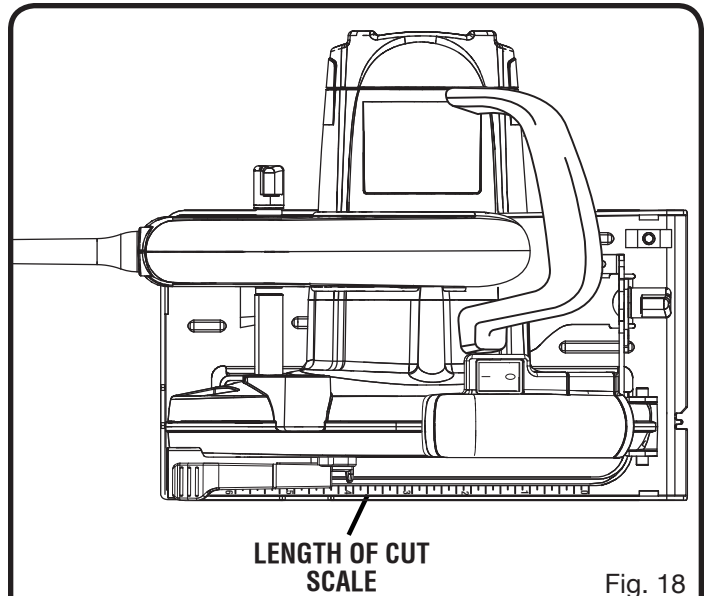

Fig. 18

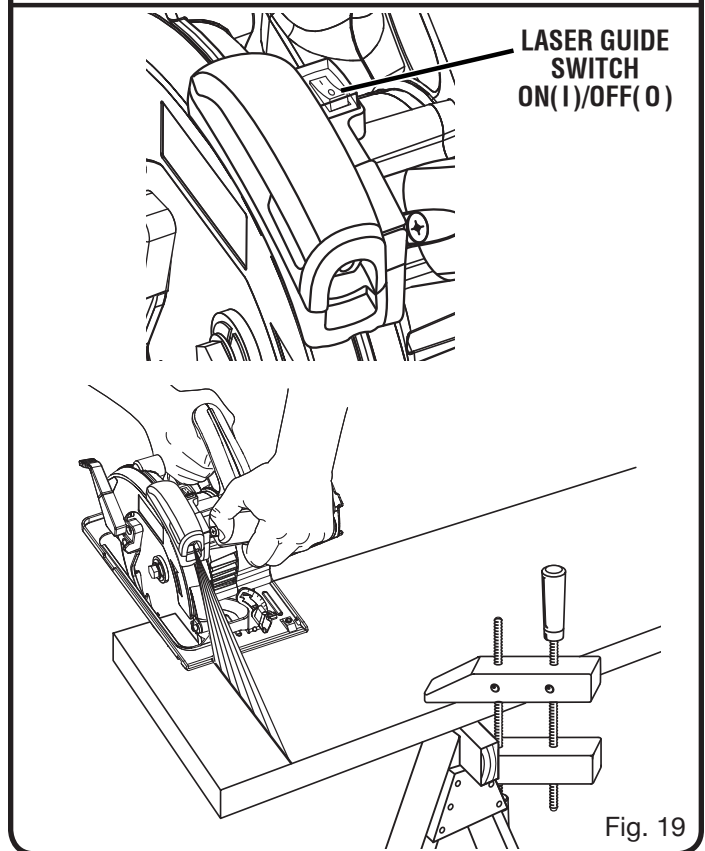

Fig. 19

OPERATION

BEVEL CUTTING

See Figures 20 - 21.

To make the best possible cut, follow these helpful hints.

- Align the line of cut with the inner blade guide notch on the base when making 45° bevel cuts.
- Make a trial cut in scrap material along a guideline to determine how much you should offset the guideline on the cutting material.
- Adjust the angle of the cut to any desired setting between zero and 51.5°. Refer to **To adjust bevel setting** next.

TO ADJUST BEVEL SETTING

See Figure 20.

- Unplug the circular saw.

⚠ WARNING:

Failure to unplug the tool could result in accidental starting causing serious injury.

- Loosen bevel adjustment knob.
- Raise motor housing end of saw until you reach desired angle setting on bevel scale.
- Tighten bevel adjustment knob securely.

⚠ WARNING:

Attempting a bevel cut without having the bevel adjustment knob securely tightened can result in serious injury.

TO BEVEL CUT

See Figure 21.

- Hold the saw firmly with both hands as shown.
- Rest the front edge of the base on the workpiece.
- Start the saw and let the blade reach full speed.
- Guide the saw into the workpiece and make the cut.
- Release the trigger and allow the blade to come to a complete stop.
- Lift the saw from the workpiece.

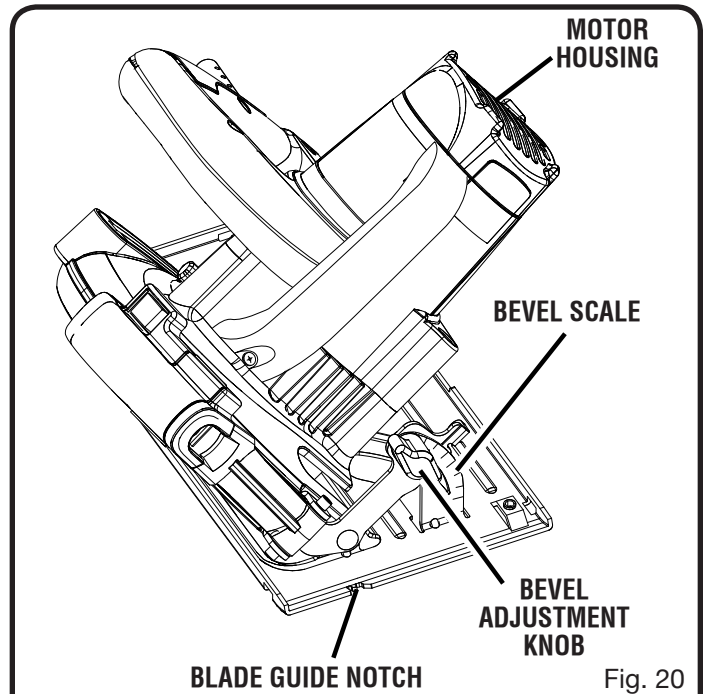

Fig. 20

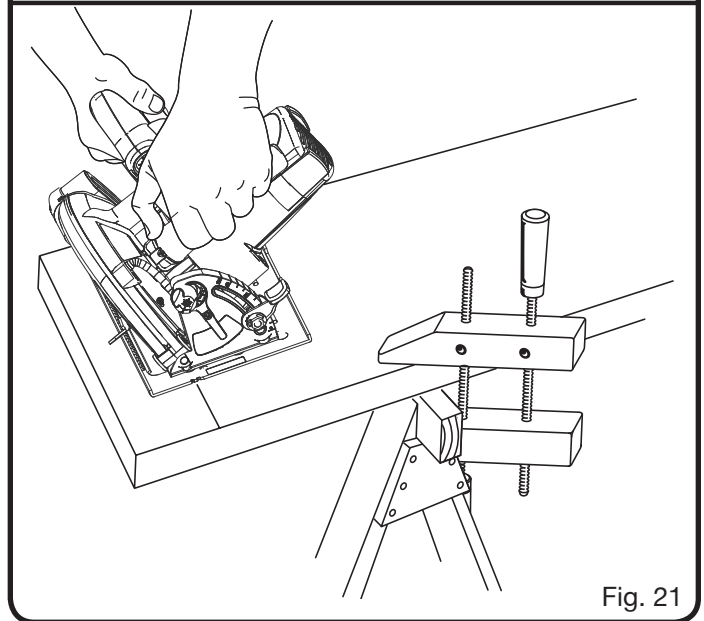

Fig. 21

OPERATION

POCKET CUTTING

See Figure 22.

⚠ WARNING:

Always adjust bevel setting to zero before making a pocket cut. Attempting a pocket cut at any other setting can result in loss of control of the saw possibly causing serious injury.

- Adjust the bevel setting to zero.
- Set the blade to the correct blade depth setting.
- Swing the lower blade guard up using the lower blade guard handle.

NOTE: Always raise the lower blade guard with the handle to avoid serious injury.

- Hold the lower blade guard by the handle.
- Rest the front of the base flat against the workpiece with the rear of the handle raised so the blade does not touch the workpiece.
- Start the saw and let the blade reach full speed.
- Guide the saw into the workpiece and make the cut.

⚠ WARNING:

Always cut in a forward direction when pocket cutting. Cutting in the reverse direction could cause the saw to climb up on the workpiece and back toward you.

- Release the trigger and allow the blade to come to a complete stop.
- Lift the saw from the workpiece.
- Clear corners out with a hand saw or sabre saw.

⚠ WARNING:

Never tie the lower blade guard in a raised position. Leaving the blade exposed could lead to serious injury.

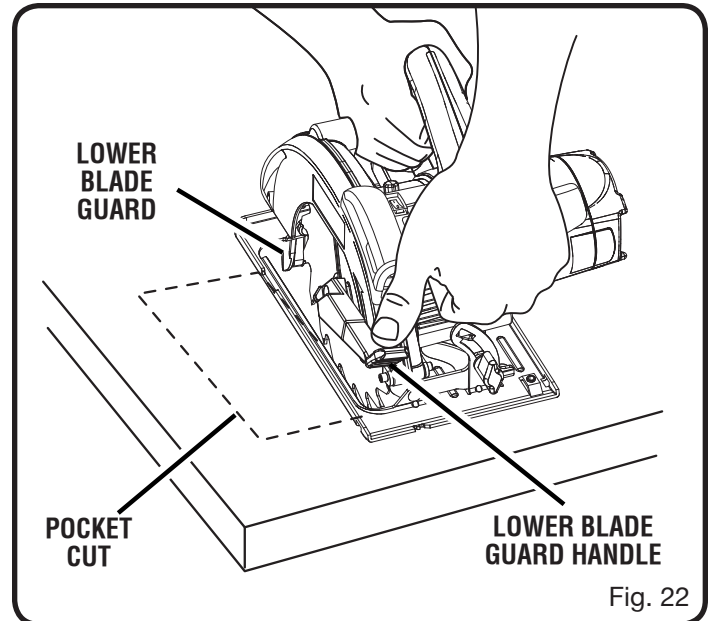

ADJUSTMENTS

⚠ DANGER:

DO NOT point the laser at yourself or others. Class IIIa lasers will burn the retinas and could cause serious injury to the eyes.

⚠ WARNING:

Before performing any adjustment, make sure the tool is unplugged from the power supply and the switch is in the **OFF (O)** position. Failure to heed this warning could result in serious personal injury.

⚠ WARNING:

Use of controls or adjustments or performance other than those specified herein could result in hazardous radiation exposure.

ADJUSTING THE LASER

See Figure 23.

- Unplug the circular saw.
- Make sure laser is turned off.
- Remove the laser cover by lifting it off its base.
- Turn laser on.
- Loosen the screw inside laser.
- Rest the front of the base on scrap workpiece.
- Adjust the laser beam with the mark on the scrap workpiece by loosening the screw to the laser aperture and slowly moving laser guide left or right.
- Since blade thicknesses vary, always make a trial cut in scrap workpiece to ensure an accurate cut.
- Once alignment is achieved tighten the screw.
- Replace the laser cover.
- Check for proper alignment.
- Repeat as necessary until laser is aligned.

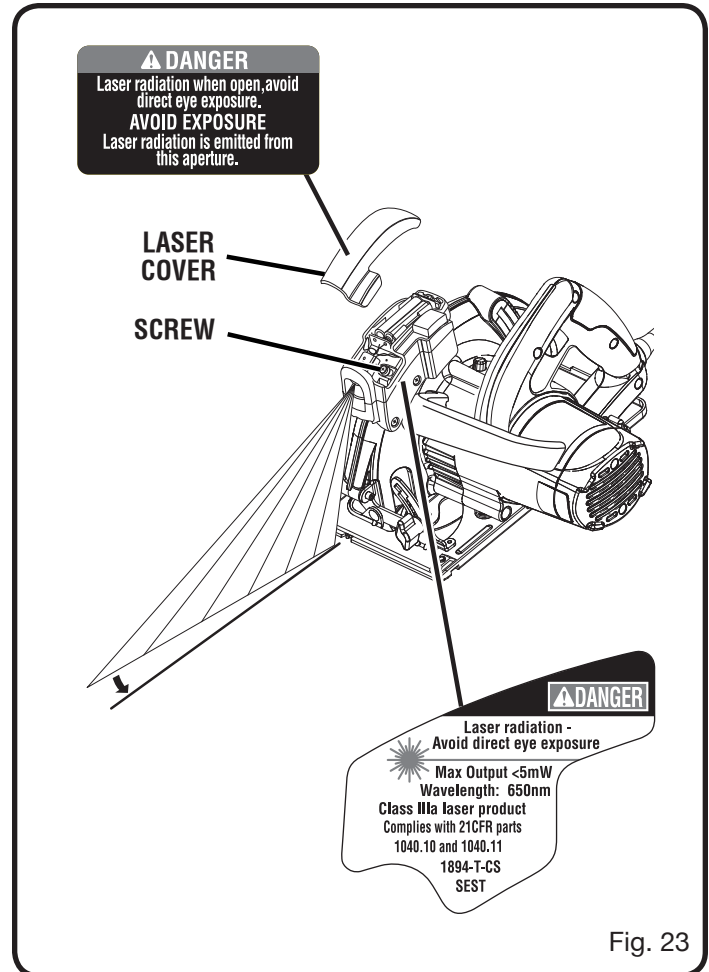

ADJUSTMENTS

0° BEVEL STOP

See Figure 24.

The saw has a 0° bevel stop that has been factory adjusted to assure 0° angle of the saw blade when making 90° cuts.

TO CHECK 0° BEVEL STOP

- Unplug the circular saw.
- Place the saw in an upside down position on a workbench.
- Check the squareness of the saw blade to the base of the saw using a carpenter's square.

TO ADJUST 0° BEVEL STOP

- Unplug the circular saw.
- Loosen bevel adjustment knob.
- Turn set screw with hex key and adjust base until it is square with the saw blade.
- Tighten bevel adjustment knob securely.

⚠ WARNING:

Attempting a bevel cut without having the bevel adjustment knob securely tightened can result in serious injury.

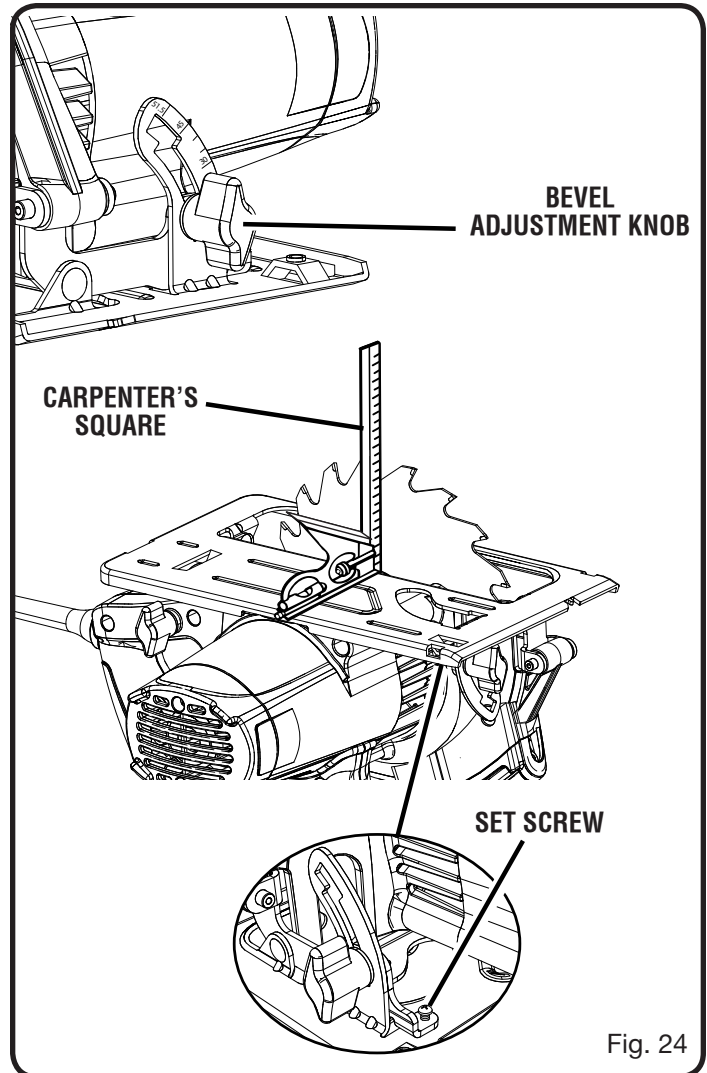

Fig. 24

MAINTENANCE

⚠ WARNING:

When servicing use only identical replacement parts. Use of any other parts may create a hazard or cause product damage.

⚠ WARNING:

Always wear safety goggles or safety glasses with side shields during power tool operation or when blowing dust. If operation is dusty, also wear a dust mask.

GENERAL MAINTENANCE

Avoid using solvents when cleaning plastic parts. Most plastics are susceptible to damage from various types of commercial solvents and may be damaged by their use. Use clean cloths to remove dirt, dust, oil, grease, etc.

⚠ WARNING:

Do not at any time let brake fluids, gasoline, petroleum-based products, penetrating oils, etc., come in contact with plastic parts. Chemicals can damage, weaken or destroy plastic which may result in serious personal injury.

Electric tools used on fiberglass material, wallboard, spackling compounds, or plaster are subject to accelerated wear and possible premature failure because the fiberglass chips and grindings are highly abrasive to bearings, brushes, commutators, etc. Consequently, we do not recommend using this tool for extended work on these types of materials. However, if you do work with any of these materials, it is extremely important to clean the tool using compressed air.

LUBRICATION

All of the bearings in this tool are lubricated with a sufficient amount of high grade lubricant for the life of the unit under normal operating conditions. Therefore, no further lubrication is required.

REPLACING LASER GUIDE BATTERIES

See Figure 25.

- Unplug the saw.
- Make sure laser is turned off.
- Remove the laser cover by lifting it off its base.
- Remove both AAA batteries.
- Install the two AAA batteries aligning the positives (+) with positives (+) and the negatives (-) with negatives (-) as shown on the inside base of laser.
- Replace the laser cover.
- Turn on laser.

⚠ CAUTION:

Use of controls or adjustments or performance other than those specified herein may result in hazardous radiation exposure.

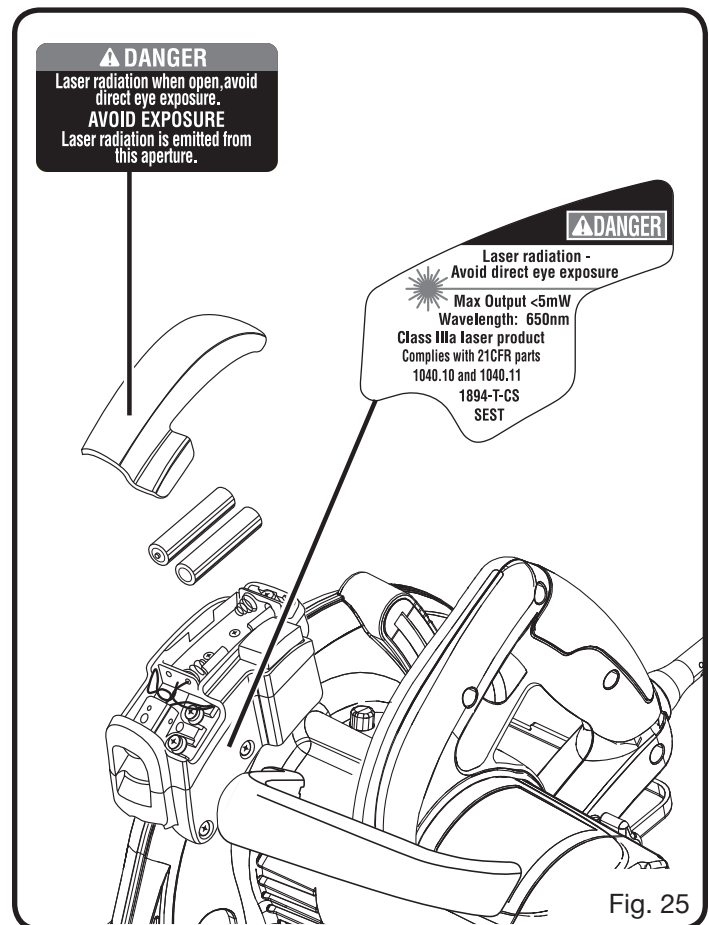

Fig. 25

